



OWNER'S MANUAL



DEFINE YOUR GREAT



Congratulations on the purchase of your Cane Creek Double Barrel rear shock. The Double Barrel brings revolutionary suspension technology to the bicycle market. Based on a foundation of precision quality and cutting-edge innovation, our rear shocks represent the pinnacle of high-performance bicycle suspension systems. Cane Creek technology offers the broadest adjustment range available giving you the control to tune your shock, your way, for your bike.

This owner's manual is your reference guide to understanding and tuning your Double Barrel rear shock. It also provides important information about proper installation, set-up and maintenance of your shock. If you have questions, visit canecreek.com or contact the Cane Creek Customer Service Team ready to help you at 800-234-2725.

**Register your shock online at
The Lounge - www.canecreek.com/lounge**



DEFINE YOUR GREAT



Getting Started

3 Safety Warnings

6 Shock Installation

DB_{INLINE}

7 Product Anatomy Chart

DB_{AIR}/DB_{AIR XV}

8 Product Anatomy Chart

DB_{AIR CS}/DB_{AIR CS XV}

10 Product Anatomy Chart

Air Shock Installation

13 Check Clearance

14 Sag Adjustment

16 Air Volume Adjustment

21 How CS Works

DB_{COIL}

22 Product Anatomy Chart

23 Check Clearance

24 Spring Selection & Installation

25 Sag Adjustment

General Information

27 Service, Maintenance & Cleaning

32 Website Resources

33 Warranty



The rear shock is an important part of your bike. Before installing and using your new rear shock, carefully read this owner's manual to learn the correct installation and adjustment procedures of the shock.

WARNING

Improperly installed and/or adjusted shocks can cause serious harm or death and may severely damage your bike.

WARNING

A broken or malfunctioning shock may cause loss of vehicle control and result in **SERIOUS INJURY OR DEATH**. If the shock ever loses oil, air or makes unusual noises, stop riding and have the shock inspected by a Cane Creek Authorized Suspension Service Center or call the Cane Creek Customer Service Team.

WARNING

Modification, improper service or use of aftermarket replacement parts voids the warranty and may cause the shock to malfunction, resulting in loss of vehicle control and **SERIOUS INJURY OR DEATH**. **Do not modify your bike frame or shock.** Use only genuine Cane Creek Double Barrel parts.

Follow service maintenance recommendations. Shock service should be performed by Cane Creek Cycling Components or a Cane Creek Authorized Suspension Service Center. Visit www.canecreek.com or contact us at 800-234-2725 to locate a Cane Creek Authorized Suspension Service Center.



**⚠ WARNING**

Cane Creek rear shocks contain a nitrogen charge in the reservoir. Opening a nitrogen pressurized shock is dangerous and can result in **SERIOUS INJURY OR DEATH**. The shock should only be opened by a Cane Creek Authorized Suspension Service Center.

⚠ WARNING

Cane Creek rear shocks are manufactured exclusively for the bike model for which they are ordered. Switching units between different bikes may not only decrease the shocks performance but might also cause damage to the bike and can result in **SERIOUS INJURY OR DEATH**. Always contact Cane Creek or Cane Creek Authorized Suspension Service Center to verify compatibility before switching a shock from one bike to another.

⚠ WARNING

Any improper servicing procedure with a Cane Creek shock with “stuck down” condition can lead to **SERIOUS INJURY OR DEATH**. Contact Cane Creek or an Authorized Suspension Service Center for repair.



⚠ WARNING

Never attempt to pull apart, open, disassemble or service a Cane Creek shock that is in a stuck down position. Stuck down is a result of a failure of the dynamic air seal (located between the positive and negative air chambers within the shock sleeve) that causes the negative chamber to retain a higher air pressure than the positive chamber. To determine if a shock is stuck down:

- a. Deflate the shock completely.
- b. If the shock body retracts into the air sleeve to a nearly bottomed-out position after the air is released from the positive air chamber, attach an air pump and inflate the shock to 200 psi (13.8 bar).
- c. If the shock does not fully extend, it is in a stuck down condition.

⚠ WARNING

When backing out your Low Speed adjuster, **BE CAREFUL NOT TO OVER-TORQUE**. When you feel resistance - **STOP**. You won't feel a hard stop, you will feel resistance. Turning farther **WILL DAMAGE YOUR SHOCK**.

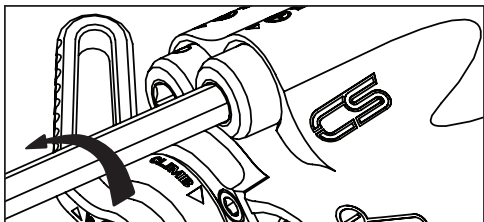

Installation - All shocks

Mounting Hardware - Your Cane Creek rear shock is equipped with exclusive high-performance, low-friction bushings and comes with mounting hardware specific to your bike's frame specifications.

- 1** Press axle into shock eyelet and end eyelet.

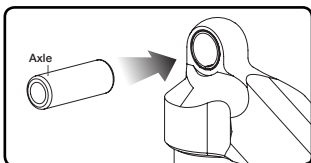

- 2** Slide spacers provided by Cane Creek over axle in the order below.

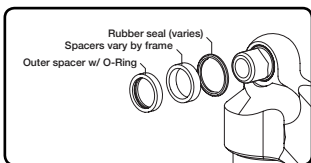

- 3** Install both mounting bolts before tightening either bolt. Then torque the mounting bolts to the frame manufacturer's suggested specification.

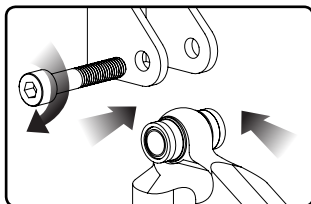

- 4** Make sure bolt is secure and no side-to-side play exists.

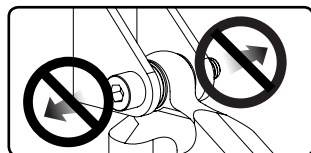

[DBAIR INLINE]

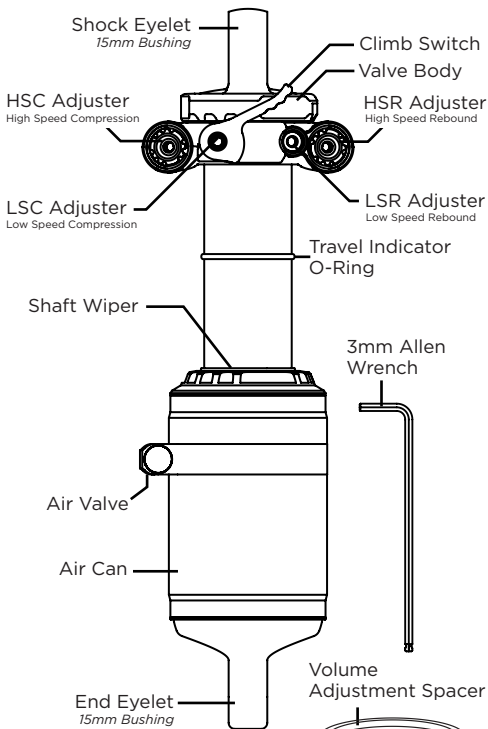

[DBAIR]

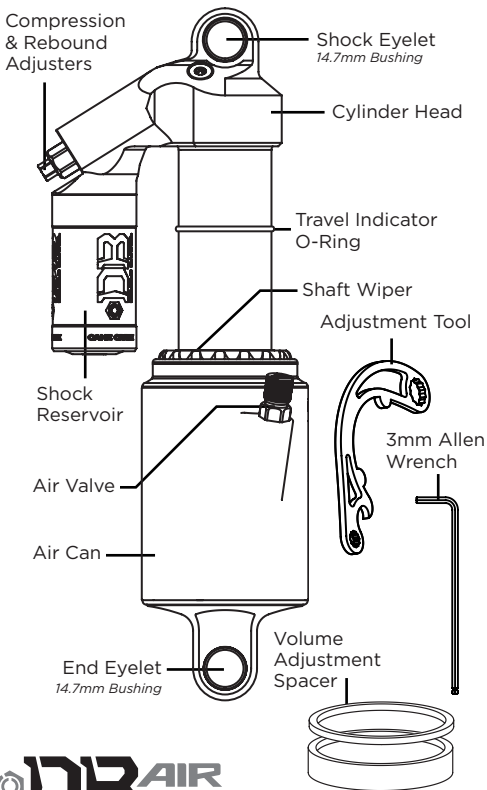

[DBAIR Xv]

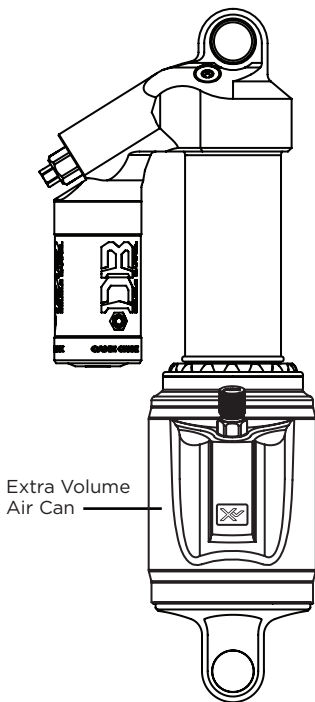

[DBAIR CS]

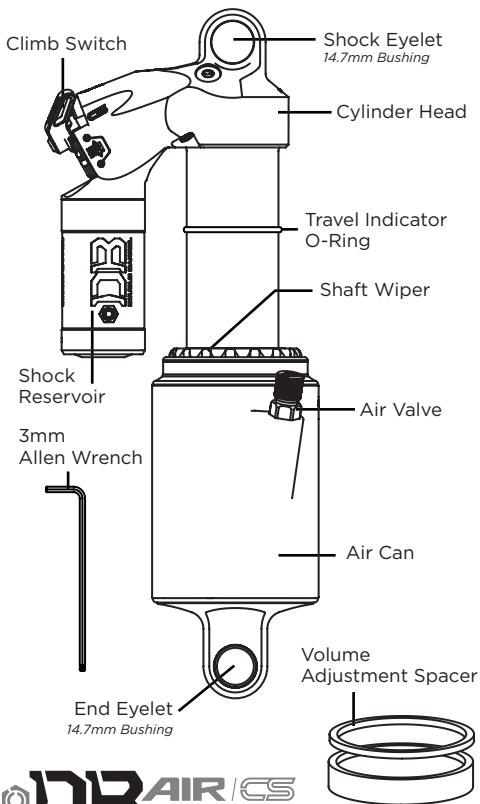

[DBAIR CS]

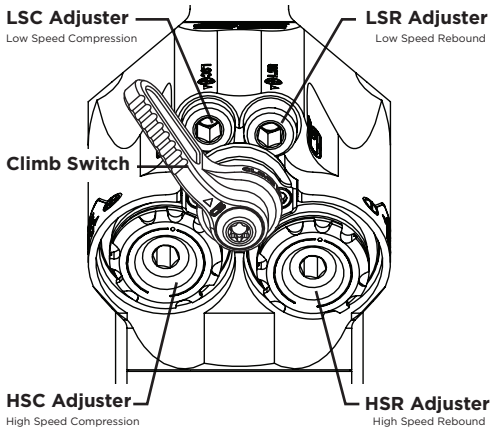

[DBAIR CS Xv] 

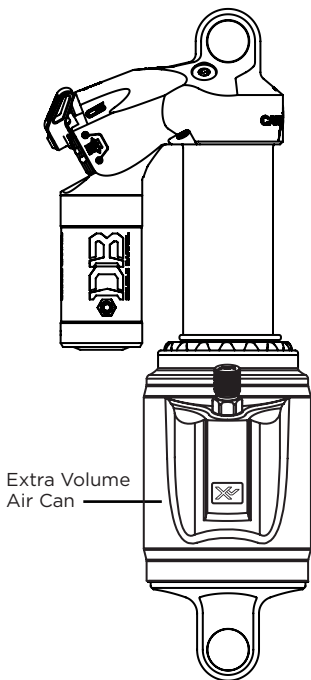

Check Frame & Shock Clearance

Before your first ride it is important to verify fitment by following the steps below.

- 1** Remove air by pressing air valve.

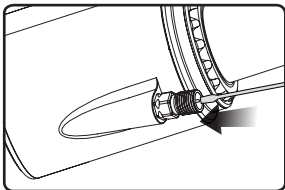

- 2** Carefully cycle shock through full travel checking for any frame interference. If there is any impediment, see canecreek.com or contact Customer Service.

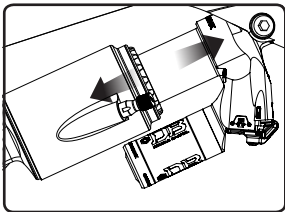

- 3** Refill shock to desired air pressure. Reinstall air valve cap.

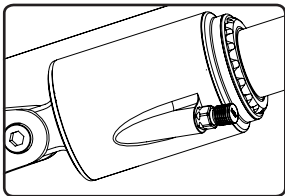

Setting Sag - DBAIR/DBAIR CS/DBINLINE

- 1 Inflate shock to starting pressure; 20 psi less than your weight (with gear) is a good starting point.

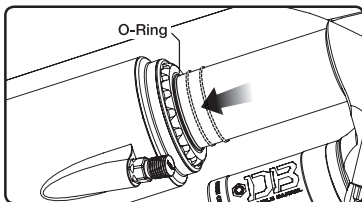

- 2 Dressed in full riding gear, mount your bicycle and assume your normal riding position. Dismount and measure the distance the O-ring has moved. This measurement is your sag. **You can find recommended sag on the Base Tune card provided with your bike or at: canecreek.com/products/suspension.**

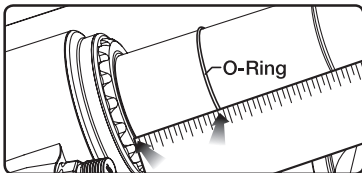

Sag = Distance from air can to O-ring.

- 3 Cycle the shock to charge the negative air spring. Recheck sag, adjust air and repeat until you have the desired measurement.

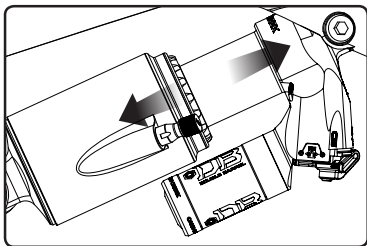



Tuning Air Volume

As an additional tuning tool, the spring rate of your air shock can be adjusted using the included air volume spacers (see Anatomy chart on pages 8-11). This is independent of the air pressure adjustment. Air pressure should be used to achieve the correct sag value (see Base Tune, Tuning Field Guide, or canecreek.com). If the bike bottoms out harshly or too frequently, an air volume spacer can control how progressive the shock is.

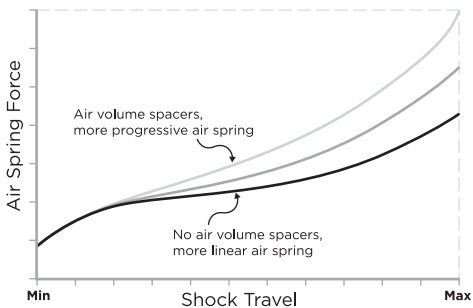

More air volume spacers will provide a more progressive air spring. A more progressive spring will prevent harsh bottom-outs, since the spring will be “stiffer” as the bike gets closer to full travel.

Fewer air volume spacers will provide a more linear (less progressive) air spring. A less progressive air spring will make it easier to use the full travel of the bike.

As air volume spacers are added to make the air spring more progressive, adding additional High Speed Rebound (HSR) will keep the bike from “bucking”. A good rule of thumb is 1/4 turn of additional HSR for each large volume spacer added.

⚠️ WARNING

Do not over torque the adjuster past its limit stop. You won't feel a hard stop, you will feel resistance. When you feel resistance - **STOP**.

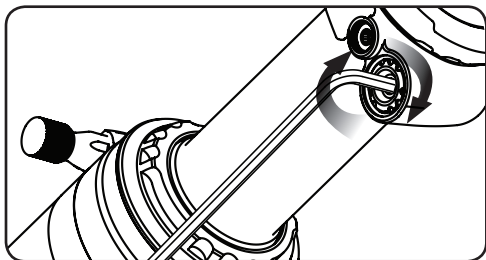
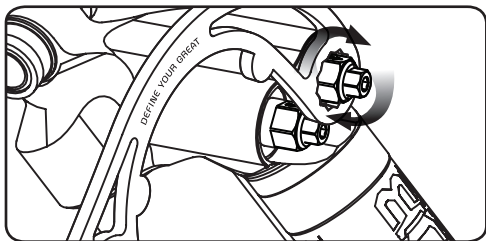

After riding your shock, if you need to change the air volume, install or remove air volume spacers:

- 1 Remove air valve cap. Press valve to remove air from air can.

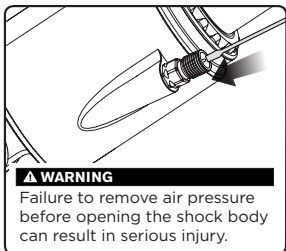

- 2 Remove shock from frame by loosening and removing mounting hardware.

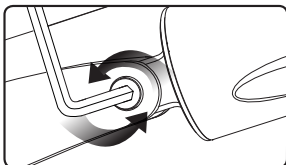

- 3 **DBAIR** - Use thumb and finger to unseat o-ring/clip ring and remove it.

DBINLINE - Hold clip ring in place with your hand and carefully pry out the clip ring.

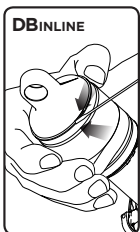
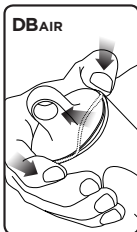

- 4 Place end eyelet of shock in vise with **padded jaws**.

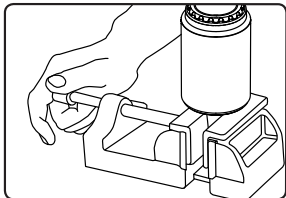

- 5** Mount rubber strap wrench. Twist while pushing down to remove air can.

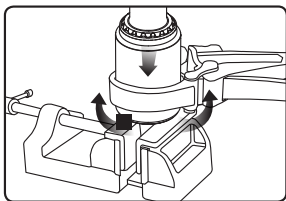

- 6** Remove shock from vise and slide air can off the end of the shock.

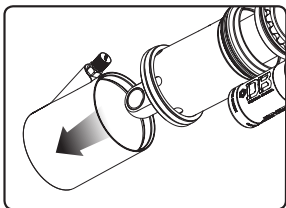

- 7** Remove the inner o-ring.

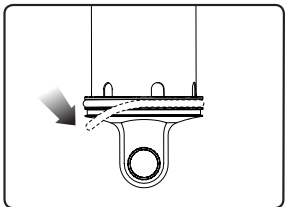

- 8** Slide air volume reduction spacer onto shock and push to the top.

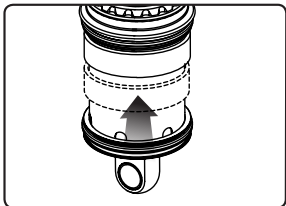

- 9** Replace inner o-ring and apply grease. Replace air can and align air valve so that it doesn't hit the frame and/or shock.

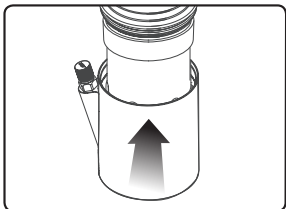

- 10** Clamp shock in **padded vise**. Use rubber strap wrench to install air can. There should be no gap between the air can and the locating shoulder.

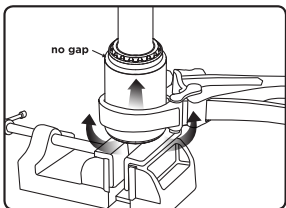

- 11** Remove shock from vise, and replace lower o-ring or clip ring.

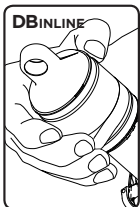
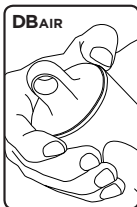

- 12** Re-install shock on bike. See page 7.

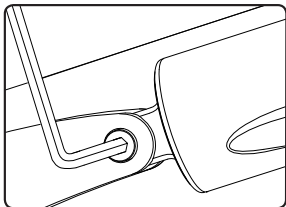

Double Barrel CS is a selectable climbing mode on Cane Creek shocks that allows you to retain the advantages of a fully-suspended bike while climbing, without unwanted suspension motion. The Climb Switch changes the low speed damping in one simple switch, to optimize suspension dynamics during climbing. When you are ready to descend, flip the CS lever and the shock returns to its externally-adjustable low-speed circuits.

Climb Switch Activation - DB_{INLINE} CS

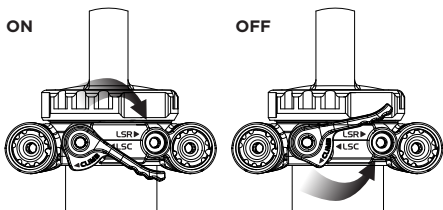

Climb Switch Activation- DB_{AIR} CS

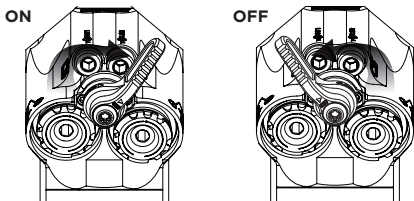

[DBCOIL]

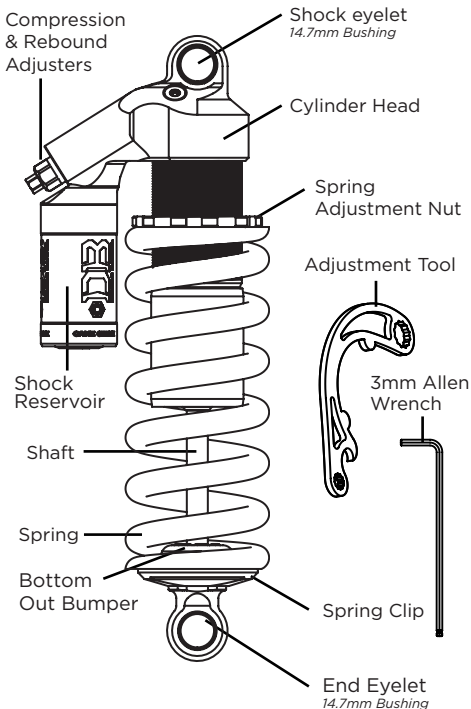

Frame & Shock Clearance: DBcoil

Before your first ride it is important to verify fitment by following the steps below.

- 1 Remove spring from the shock (see instructions on next page).

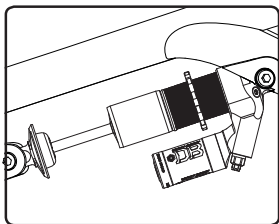

- 2 Carefully cycle shock through full travel checking for free movement without restriction.

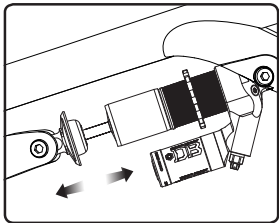

- 3 Reinstall the spring and attach shock to frame.

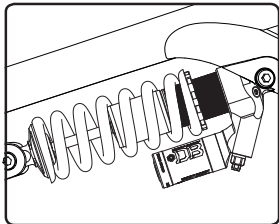

Spring Selection & Installation

Spring Selection

Selecting the appropriate spring rate is an important variable in achieving optimal set-up of the DBCOIL. Your ideal spring rate will be based on rider weight, frame design, and riding style. (See our online calculator at canecreek.com or call the Cane Creek Service Team).

⚠ WARNING

Riding on a spring that is not appropriate for your body weight can cause **SERIOUS INJURY OR DEATH** and damage to the bike and shock.

Spring Removal and Installation

To remove the spring, turn the spring adjustment nut until it touches the cylinder head. Remove spring clip from shock. Once the clip is removed, slide the spring off the shock. On frames with long mounting axles, it will be necessary to remove the mounting axle before the spring can be removed.

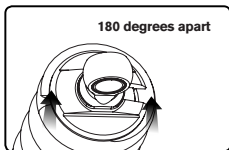
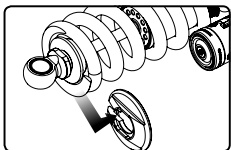

⚠ WARNING

Always make sure the end of the spring's coil is aligned on the opposite side of the slot in the spring clip.

Setting Sag - DBcoil

Preload affects the energy in the spring.

IMPORTANT If less than 1 turn of preload is needed to achieve proper sag, you will need to change to a lower spring rate. If more than 6 turns of preload are needed to achieve proper sag, you will need to change to a stiffer (higher rate) spring.

Increasing Spring Preload

Increasing the preload will increase the ride height and reduce sag. To increase the preload on your spring, turn the Spring Adjustment Nut clockwise (no more than six turns).

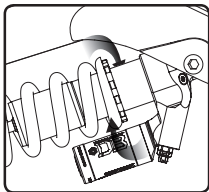

Reducing Spring Preload

Reducing the preload will decrease the ride height and increase sag. To reduce the preload on your spring, turn the Spring Adjustment Nut counter-clockwise (no less than one turn).

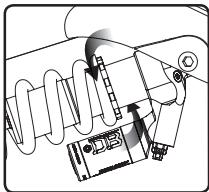

Setting Sag - DBcoil

To Measure Sag

1. Make sure that you are on a level surface. With the rear wheel off the ground, measure the length of your shock from eye-to-eye.
2. Dressed in full riding gear, mount your bicycle and assume your normal riding position. Measure the shock length again from eye-to-eye.

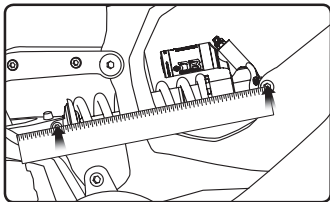

3. The difference between the two measurements is the sag. **See Base tune for proper sag setting.**

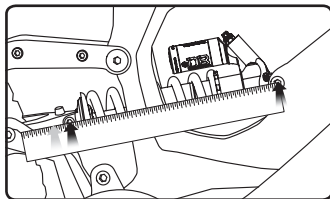





Service, Maintenance, and Cleaning

Cane Creek Double Barrel rear shocks are designed for long-term durability, though some simple maintenance steps can ensure long life and smooth function. If you ride in extreme weather conditions, the service intervals should be more frequent.

Service should only be performed by a Cane Creek Authorized Service Center. Visit www.canecreek.com or call the Cane Creek Customer Service Team at 800-234-2725 to locate a service center near you.

IMPORTANT NOTES

-  **Do not use compressed air to clean any Double Barrel shock.**
-  **Do not use any solvents or de-greasers, as these products can damage the shock's exterior finish or its anodized parts.**
-  **Do not spray water directly at any seal.**
-  **Never use a high-pressure washer on your rear shock.**

Before every ride, check that the mounting hardware is tight and ensure there is no play between the mounting bushings and the mounting hardware. If there is movement, you may need to replace your shock bushings.

To replace shock bushings, a Cane Creek bushing replacement tool kit (DBT024) is required. This can also be performed by your bike dealer or Cane Creek Authorized Service Center. **Using a non-Cane Creek bushing replacement tool will damage your shock.**

For cleaning, use mild soapy water, a very light pressure water spray to rinse, and wipe dry with a clean, dry cloth.

Check for any oil leaks. If you are unsure if there is a leak or simply a seepage of assembly grease, clean the shock with mild soapy water and recheck the suspect area after riding.



Service and Maintenance Schedule

	Each ride	Every 15 Hrs	Every 100 Hrs
Check sag - reset if necessary	X		
Clean and inspect shock exterior, including travel-indicating o-ring. Clean with mild soap and water.	X		
Inspect external air sealing surfaces for scratches, dents or other damage.	X		
Inspect and clean air valve threads to prevent dirt from entering air spring during inflation.		X	
Inspect mounting hardware and bushings.		X	
Air spring service. Must be performed by a Cane Creek Authorized Service Center.			X or Semi-annual
Service damper. Must be performed by a Cane Creek Authorized Service Center.			X





Service and Maintenance Schedule

	Each ride	Every 15 Hrs	Every 100 Hrs
Check sag - reset if necessary	X		
Clean and inspect shock exterior, including travel-indicating o-ring. Clean with mild soap and water.	X		
Inspect external air sealing surfaces for scratches, dents or other damage.	X		
Inspect and clean air valve threads to prevent dirt from entering air spring during inflation.		X	
Inspect mounting hardware and bushings.		X	
Air spring service. Must be performed by a Cane Creek Authorized Service Center.			X or Semi-annual
Service damper. Must be performed by a Cane Creek Authorized Service Center.			X





Service and Maintenance Schedule

	Each ride	Every 15 Hrs	Every 100 Hrs
Check sag - reset if necessary	X		
Each ride, clean and inspect shock exterior. Clean with mild soap and water.	X		
Clean around spring adjustment nut to prevent damage to the threads on shock body.		X	
Inspect mounting hardware and bushings.		X	
Service damper. Must be performed by a Cane Creek Authorized Service Center.			X





Suspension is personal. Double Barrel shocks offer an unsurpassed range of tuning. On an individual basis, there is no secret formula to determine the tune that best works for each rider. The Double Barrel allows for custom tuning for any bike right out of the box. Because no one knows your ride better than you, we offer online resources in three critical components that allow you to DEFINE YOUR GREAT.

BASE TUNES

Frame specific recommended settings. Search by bike make & model at:

www.canecreek.com/products/suspension

TUNING FIELD GUIDE

This road map to fine tuning will walk you through the simple steps of personalized suspension set-up. Find it online at:

www.canecreek.com/tech-center/suspension/manuals

THE LOUNGE

The place to register your shock, connect with Cane Creek and tap into the vast knowledge base of Double Barrel riders.

www.canecreek.com/products/suspension/lounge





LIMITED ONE (1) YEAR WARRANTY ON SUSPENSION PRODUCTS

Subject to the limitations, terms and conditions here of, Cane Creek warrants, to the original retail owner of each new Cane Creek suspension product, that the Cane Creek suspension product, when new, is free from defects in materials and workmanship. This warranty expires one (1) year from the date of the original Cane Creek suspension product retail purchase from an authorized Cane Creek dealer or from a Cane Creek authorized original equipment manufacturer where Cane Creek suspension is included as original equipment on a purchased bike, unless otherwise dictated by requirement of law.

TERMS OF WARRANTY

This warranty is conditioned on the Cane Creek suspension product being operated under normal conditions and properly maintained as specified by Cane Creek. This warranty is only applicable to Cane Creek suspension purchased new from an authorized Cane Creek source and is made only to the original retail owner of the new Cane Creek suspension product and is not transferable to subsequent owners. This warranty is void if the Cane Creek suspension product is subjected to abuse, neglect, improper or unauthorized repair, improper or unauthorized service or maintenance, alteration, modification, accident or other abnormal, excessive, or improper use. Should it be determined, by Cane Creek in its sole and final



discretion, that a Cane Creek suspension product is covered by this warranty, it will be repaired or replaced, by a comparable model, at Cane Creek's sole option, which will be conclusive and binding.

THIS IS THE EXCLUSIVE REMEDY UNDER THIS WARRANTY. ANY AND ALL OTHER REMEDIES AND DAMAGES THAT MAY OTHERWISE BE APPLICABLE ARE EXCLUDED, INCLUDING, BUT NOT LIMITED TO, INCIDENTAL OR CONSEQUENTIAL DAMAGES OR PUNITIVE DAMAGES.

This limited warranty does not apply to normal wear and tear, malfunctions or failures that result from abuse, improper assembly, neglect, alteration, improper maintenance, crash, misuse or collision. Subject to the terms and conditions of this warranty, leaking seals will be replaced within 90 days from the original date of purchase. Such replacement notwithstanding, seals are subject to relative movement between parts and are normal wear-and-tear items not subject to warranty coverage.

This limited warranty gives the consumer specific legal rights. The consumer may also have other legal rights which vary from state to state or country to country. Some states and countries do not allow the exclusion or limitation of incidental or consequential damages or warranties, so the above limitations or exclusions may not apply to you. If it is determined by a court of competent jurisdiction that a certain provision of this limited warranty does not apply, such determination



shall not affect any other provision of this limited warranty and all other provisions shall remain in effect.

THIS IS THE ONLY WARRANTY MADE BY CANE CREEK ON ITS SUSPENSION PRODUCTS AND COMPONENTS, AND THERE ARE NO WARRANTIES THAT EXTEND BEYOND THE DESCRIPTION HEREIN. ANY WARRANTIES THAT MAY OTHERWISE BE IMPLIED BY LAW INCLUDING, BUT NOT LIMITED TO, ANY IMPLIED WARRANTY OF MERCHANTABILITY OR FITNESS FOR A PARTICULAR PURPOSE ARE EXCLUDED.



DATE/TRAIL/CONDITIONS

RIDING WEIGHT

SHOCK AND STROKE LENGTH

SAG

SPRING RATE / AIR PRESSURE

HSC [HIGH SPEED COMPRESSION]**LSC** [LOW SPEED COMPRESSION]**HSR** [HIGH SPEED REBOUND]**LSR** [LOW SPEED REBOUND]